



211 Horn Lane
 West Monroe, LA 71292
 Phone: 800-551-4955
 or 318-322-3458
 FAX: 318-323-5995

INSTALLATION INSTRUCTIONS

Superrunner Replacement Steering Linkage for 4WD Ford Ranger, Explorer - Part Numbers 1124 and 1134

This product is intended to be used with Superlift's 4" or 5.5" suspension lift systems. It *should* be compatible with any 3" to 6" suspension. This product must not be used on any suspension lift in excess of 6".

- NOTES:**
- The vehicle must be equipped with a "dropped" pitman arm with specific dimensions; refer to Step 2 and Diagram 1.
 - Installation requires a professional mechanic. Prior to beginning, carefully inspect the vehicle's steering and driveline systems paying close attention to the ball joints, and wheel bearing preload. Also check steering-to-frame and all suspension-to-frame attaching points for stress cracks. The overall vehicle must be in excellent working condition; repair or replace all worn parts.
 - Read instructions several times before starting. Be sure you have all needed parts and know where they install. Read each step completely as you go.
 - A foot pound torque reading () is given after each appropriate fastener.
 - Front end realignment is necessary

PARTS LIST

Prior to disassembly, identify each part, and place the appropriate mounting hardware with it. Contact your Superlift dealer if any components are missing.

PART NO.	DESCRIPTION (Quantity - if more than one)	NEW ATTACHING HARDWARE (Quantity)
55-04-1124	idler arm	(4) bushing halves (2) bushing wear sleeves (2) 9/16" x 4 1/2" bolt (2) 9/16" stover type lock nut
55-05-1124	idler arm mounting bracket	(1) 7/16" x 1 1/2" Gr. 8 bolt (1) 7/16" Gr.8 lock nut (1) 7/16" extra-thick flatwasher

REMAINING COMPONENTS: NOTE:• All tie rods include a grease boot and fitting, cotter pin, and nut.

1-11-1124	driver side inner tie rod, 17 9/16" long	
1-07-1024	driver side outer tie rod end, 20 mm diameter threads	
09-1024	driver side adjustment sleeve, 20 mm	
1-12-1124	passenger side inner tie rod, 15 1/4" long	
1-06-1024	passenger side outer tie rod end, 22 mm diameter threads	
10-1024	passenger side adjustment sleeve, 22 mm	
55-03-1124	centerlink	

- 1) Remove stock steering linkage.
- 2) **PITMAN ARM** - Install new Superlift pitman arm, per separate instructions. If vehicle is already equipped with a "dropped" pitman arm, compare its dimensions to those in Diagram 1. If the arm's measurements do not fall in the ranges noted, you must purchase a new Superlift arm.
- 3) **IDLER MOUNTING BRACKET [DIAGRAM 2]** - The bracket mounts to the top of the front crossmember via existing axle pivot bracket attaching points. Loosen the two nuts on stock fastener 'A'. Since clearance between 'A' and the engine is minimal, the idler bracket is slotted so the fastener does not need to be completely removed. Remove and discard existing bolt 'B'. Hole 'C' is an additional mounting point found on Superlift Suspensions and may not be present with other brands. If hole 'C' must be drilled, position / fit check the idler bracket, then carefully measure or make a bolt pattern template, and drill through the axle pivot bracket and crossmember from the bottom. After drilling, file smooth any burrs or raised edges or stress cracks may develop.

Prior to bolting idler bracket-to-crossmember, thoroughly clean the mating surfaces.

Torque: stock fastener A . . . (77-110), stock fastener B . . . (77-110), new bolt C . . . (52)

3 continued . . .) NOTE: With automatic transmissions, two metal transmission fluid lines must be carefully reformed and rerouted to clear the idler bracket. Route the lines so that no metal-to-metal contact exists.

4) IDLER ARM - Insert eye bushings into both ends of the idler. Prior to inserting the wear sleeves, coat the sleeves' O.D. with a light Lithium based grease. Connect idler to its mounting bracket with the 9/16" x 4" bolt, pointing downward, and locking nut (40). The idler installs with the tube body offset as shown in Diagram 3.

5) CENTERLINK - Connect the centerlink-to-pitman arm first. Lubricate the end, torque nut (60), and install cotter pin. Now, attach the idler-to-centerlink with the 9/16" x 4" bolt, pointing downward, and locking nut (40).

6) CENTERING THE STEERING WHEEL AND SECTOR - Rotate the steering wheel full-lock to the right. Now turn the wheel full-lock left, counting the number of rotations. Turn the wheel back to the right, one-half the number of total rotations. During this procedure, inspect the linkage for adequate clearance and bind-free operation.

The pitman arm / steering sector is now centered, and the steering wheel crossbars should be properly positioned.

7) TIE ROD PREASSEMBLY [DIAGRAM 4] - The tie rods must be assembled and installed on the vehicle as shown in Diagram 4. Inverted installation can cause end failure due to tie rod pivot stud overextension.

Note that the driver side assembly has 20 mm diameter end threads, while the passenger side takes 22 mm ends. Each assembly consists of a long inner end and a short outer end coupled by an adjustment sleeve. Preassemble each side by screwing the ends into the appropriate adjustment sleeve for 4-5 full rotations. Now lubricate all ends via their grease fittings.

8) TIE ROD INSTALLATION - This operation should be performed with vehicle weight on the suspension. Perform a rough toe-in setting by equalizing the front-of-tire and rear-of-tire track width measurements.

On the driver's side, attach the knuckle end of tie rod assembly and, while holding the unsecured inner end stationary, rotate the adjustment sleeve until the proper length is achieved. **NOTE: To ensure adequate thread engagement, each end must have no less than 1 5/16" of thread engagement into the adjustment sleeve.**

Adjust and attach the passenger's side tie rod assembly in the same manner. Torque each end (60) and install furnished cotter pins. Also torque the adjustment sleeve nuts (42). **NOTE: Before tightening the adjustment sleeve bolts, be sure the tie rod end bodies are in line (not rotated) with their pivot studs. Refer to Diagram "A".**

9) FINAL PROCEDURES - Recheck all fasteners for proper tightness. Put transmission in neutral. Raise front of vehicle with a locking pneumatic bumper jack, or secure jack stands underneath the frame horns, directly behind front bumper. Put vehicle in park or gear (for manual transmissions), set emergency brake, and chock rear wheels to prevent any possibility of movement.

With the front suspension unloaded and hanging, fully cycle steering left-to-right while inspecting the steering for proper operation and clearance.

Lower vehicle to floor, and with the suspension supporting vehicle weight, repeat the cycling inspection procedure.

10) ALIGNMENT - Set toe-angles to factory specifications.

IMPORTANT PRODUCT USE INFORMATION

As a general rule, the taller a vehicle is, the easier it will roll. Offset, as much as possible, what is lost in rollover resistance by increasing tire track width. In other words, go "wide" as you go "tall". Many sportsmen remove their mud tires after winter/hunting season and install ones more appropriate for street driving; always use as wide a tire and wheel combination as possible to enhance vehicle stability.

We strongly recommend, because of rollover possibility, that the vehicle be equipped with a functional roll-bar and cage system. Seat belts and shoulder harnesses should be worn at all times. Avoid situations where a side rollover may occur.

Generally, braking performance and capabilities are decreased when significantly larger/heavier tires and wheels are used. Take this into consideration while driving. Also, taller tires degrade speedometer accuracy. Unless the speedometer is recalibrated, the vehicle will be traveling faster than indicated.

Do not add, alter, or fabricate any factory or aftermarket parts to increase vehicle height over the intended height of the Superlift product purchased. Mixing component brands is not recommended.

Most states have some type of law limiting vehicle height. The amount of lift allowed, and how the lift can be achieved, varies greatly. Several states offer exemptions for farm or commercial registered vehicles. It is the owner's responsibility to check state and local laws to ensure that their vehicle will be in compliance.

Superlift makes no claims regarding lifting devices and excludes any and all implied claims. Superlift will not be responsible for any altered product or any improper installation or use of our products.

We will be happy to answer any questions concerning the design, function, and correct use of our products.

IMPORTANT MAINTENANCE INFORMATION

It is the ultimate buyer's responsibility to have all bolts/nuts checked for tightness after the first 100 miles and then every 1000 miles. Wheel alignment, steering system, suspension and driveline systems must be inspected by a qualified professional mechanic at least every 3000 miles.

NOTICE TO DEALER AND VEHICLE OWNER

Any vehicle equipped with a Superlift lifting device should have a "Warning to Driver" decal (included in all lifting device's kit box) installed on the inside of the windshield or on the vehicle's dash, within driver's view. The "Warning to Driver" decal is to act as a constant safety reminder for whoever may be operating the vehicle. The WARRANTY IS VOID unless this decal is in place. INSTALLING DEALER . . . It is your responsibility to install warning decal and forward these installation instructions to the vehicle owner for review of warnings, product use and maintenance information. These instructions are to be kept with the vehicle registration papers and owner's manual for the service life of the vehicle.

SUPERLIFT LIMITED LIFETIME WARRANTY

Suspension products bearing the Superlift (LKI Ent.) name are warranted for as long as the original purchaser owns the vehicle that the LKI product was originally installed on. This warranty is non-transferable. Warranty covers only the product, no labor, time loss, or freight incurred. Any product that has been abused, altered, incorrectly installed, or used in competition is not covered. Product finish, spring bushings, Polyurethane products, and normal wear is not covered. The LKI product is subject to replacement or repair. No other warranties are expressed or implied.

An authorized Superlift dealer must inspect the part in question and confirm that the "Warning to Driver" decal is properly displayed. A copy of the sales invoice is required for warranty consideration.

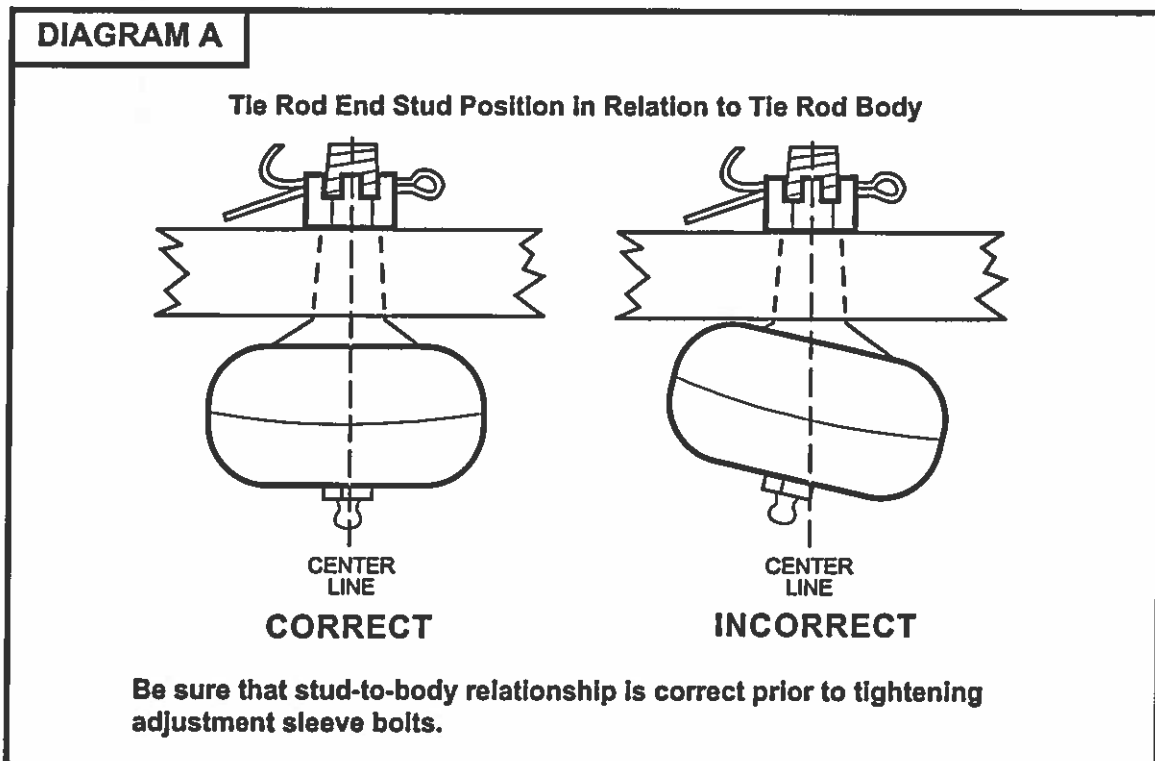

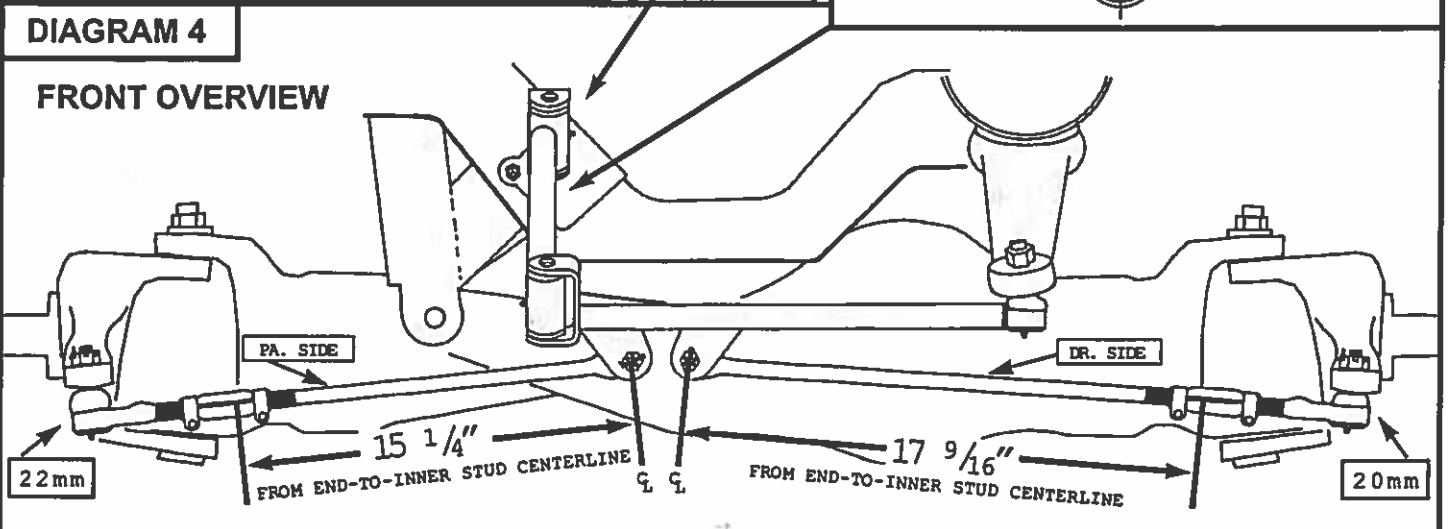
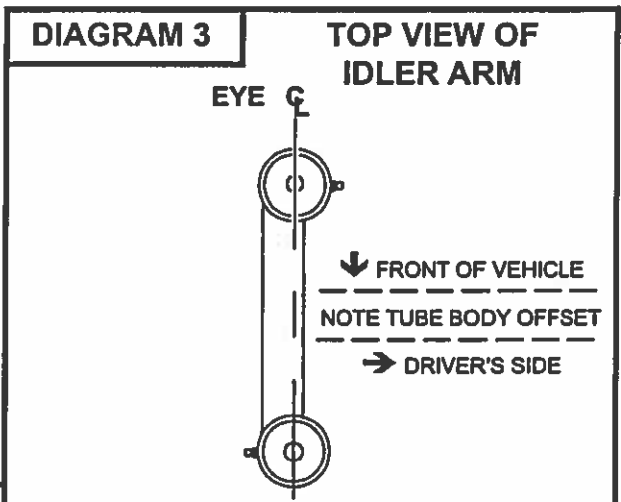
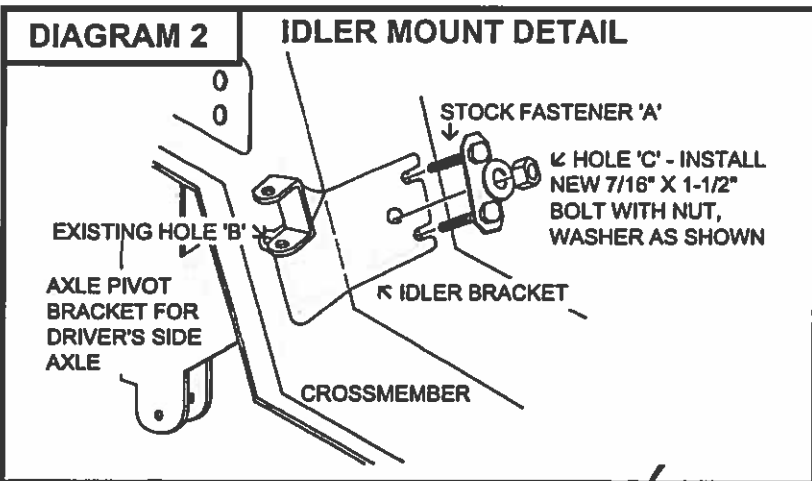
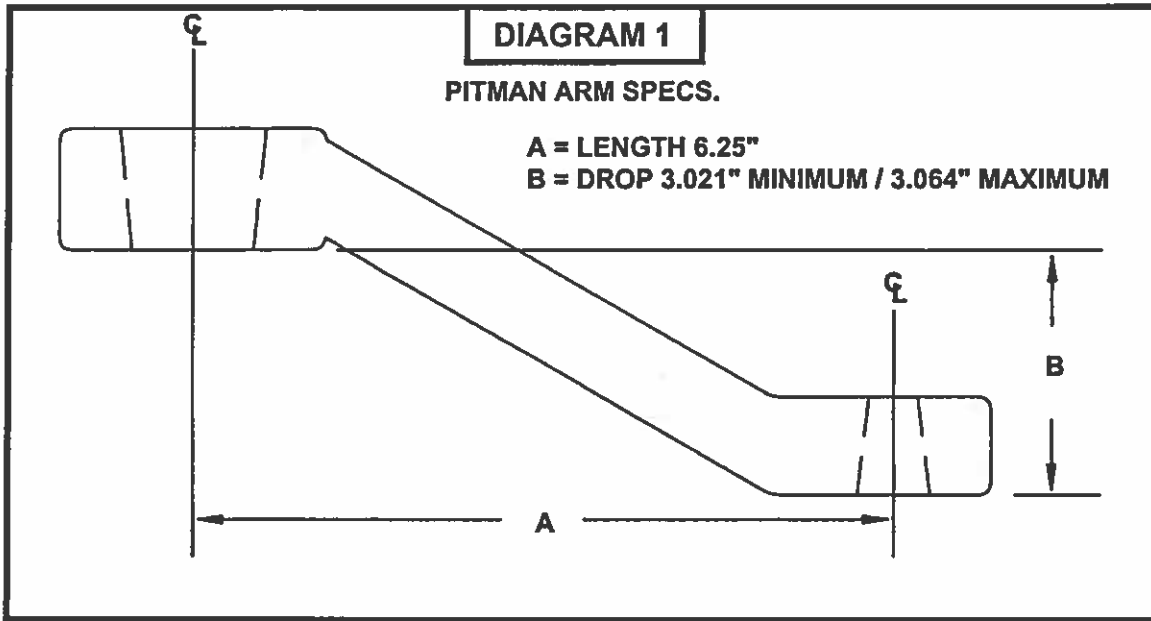

NOTE: For adequate thread engagement, each end must have no less than 1 5/16" of thread engagement into the adjustment sleeve. Torque adjustment sleeve clamp bolts to 42 ft. lbs.